

WARRANTY

1. Subject to clauses 2 & 3 of this warranty, A.F. Gason Pty Ltd. ACN 004 667 556 warrants the following components of its heaters against defects in workmanship and/or materials for the following periods from the date of purchase:
 - a) the firebox for ten years;
 - b) the paint finish for a period of 12 months if the purchaser has followed the instructions provided by Gason in the operation and Installation Instructions manual; and
 - c) all other components for 12 months except the glass, fire brick lining or baffle plate if, in the opinion of Gason, these items have been damaged by impact.
2. This extended warranty does not apply:
 - a) if the heater is purchased from a person who has not been authorised by Gason to sell its products;
 - b) if, in the opinion of Gason, the heater or any other component has been subject to abuse, misuse, alteration, modification or has not been installed, operated or maintained in accordance with the instructions provided by Gason; or,
 - c) to owners other than the original purchaser.
3. If you believe that the heater you purchased contains a manufacturing defect and you wish to make a claim under this warranty, please contact an authorised Gason service centre to arrange for an assessment.
 4. If, after assessing the heater, Gason determines that the heater contains a manufacturing fault, Gason may at its discretion:
 - a) replace the heater;
 - b) repair or replace specific components of the heater; or
 - c) provide a full refund.
 5. Parts replaced under warranty are warranted for the balance of their original warranty period.
 6. If, at the discretion of Gason, the heater or any part needs to be replaced, serviced or repaired at an authorised Gason service centre, then the person claiming under this warranty must pay all costs associated with:
 - a) returning the heater; and
 - b) the delivery or collection of any new or repaired heater.

Our goods come with guarantees that cannot be excluded under the Australian Consumer Law. You are entitled to a replacement or refund for a major failure and for compensation for any other reasonably foreseeable loss or damage. You are also entitled to have the goods repaired or replaced if the goods fail to be of acceptable quality and the failure does not amount to a major failure.

Any benefits you receive under these warranties are in addition to other rights and remedies that you may have as a consumer under law in relation to the heater to which these warranties relate.

These warranties are given by:

AF Gason Pty Ltd
Blake Street
Ararat VIC 3377

Please contact us if you have any queries on:
Phone: 03 97633200
or email us via the "Contact Us" section of our website: www.gason.com.au



Eureka[®]
Woodheating

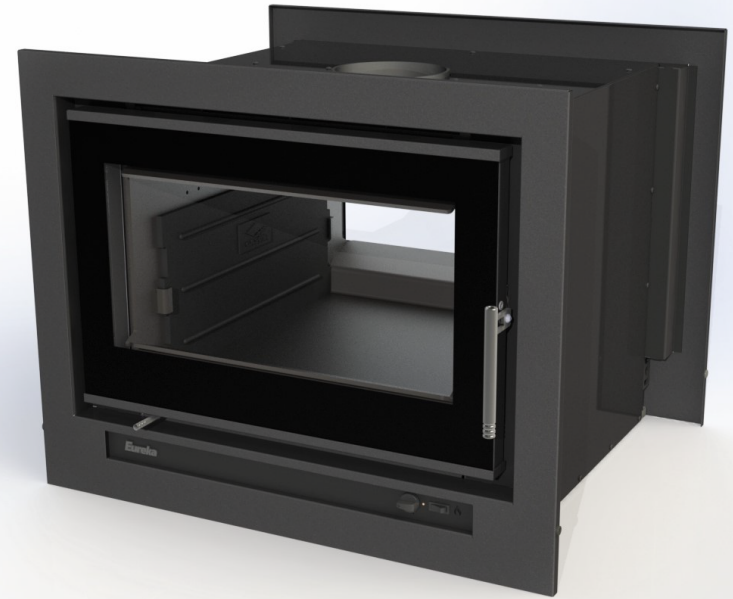

Jewel Insert

Operation & Installation Instructions

Rev B

Please keep these instructions for future reference.

234438



WARNING

Read and follow these instructions carefully before installing and using this appliance.

To aid heater installation, remove door, baffle system and cast iron liners to reduce overall heater weight.



WARNING

Safety Warnings

- A flue fire with resulting damage may occur if the appliance is not installed, operated and maintained as per this booklet.
- Never place combustible materials such as wood, paper or furniture near the appliance.
- This appliance is designed to burn dry wood. Do not burn rubbish, driftwood, flammable liquids or any substance containing salts or corrosives.
- This appliance must not be installed and operated in an area where kerosene, petrol, paint thinner or other flammable liquid is used or stored.
- The flue system must be inspected and cleaned annually or sooner if required. Failure to do so could result in an excessive buildup of creosote which may result in a flue fire, which may damage the flue or cause damage to your home.
- The surface of the appliance becomes hot during operation. Do not touch the surface of this appliance. Keep children away from this appliance during operation. Do not allow anyone to operate this appliance who is not familiar with this instruction booklet.



WARNING

Paint Curing and Care

Your heater is coated with the best available heat resistant paint. Even though the paint has been baked after application, it may require further temperature curing. It may, if you overfire the heater on its first fire, discolour. For your first two or three firings, never exceed Medium air setting and always have the fan on when above low burn. Do not wipe the heater while the paint is curing. After the paint has cured the only maintenance required to maintain the heater's finish is to wipe it with a soft cloth. Do not use any commercial cleaners or solvents on the paint finish.

We are proud of the presentation of our products. If at any time you need to freshen up the paint, your local dealer has touchup paint available for purchase.

This heater is painted in stovebrite Metallic Black - code 6309.

If you have any enquiries, please contact the dealer from whom you purchased your heater:

PLEASE COMPLETE:

Dealer Name: _____ Phone: _____

Dealer Address: _____

Dealer Email: _____

Please attach your original purchase dockets to this booklet for future reference.

PAGE INTENTIONALLY BLANK

Removing heater from pallet:

- Remove 4 x Phillips Head screws holding the transport brackets to the side of the unit.
- Discard transport brackets and Tek Screws used to fasten them to the pallet.
- Re-fit 4 x Phillips Head screws to side panels of heater in the original holes.

O/All weight: 240kg

Package dimensions: 910Hx910Wx1000D

To aid heater installation, remove doors, top plate, baffle and cast iron liners to reduce overall heater weight.

Figure 11

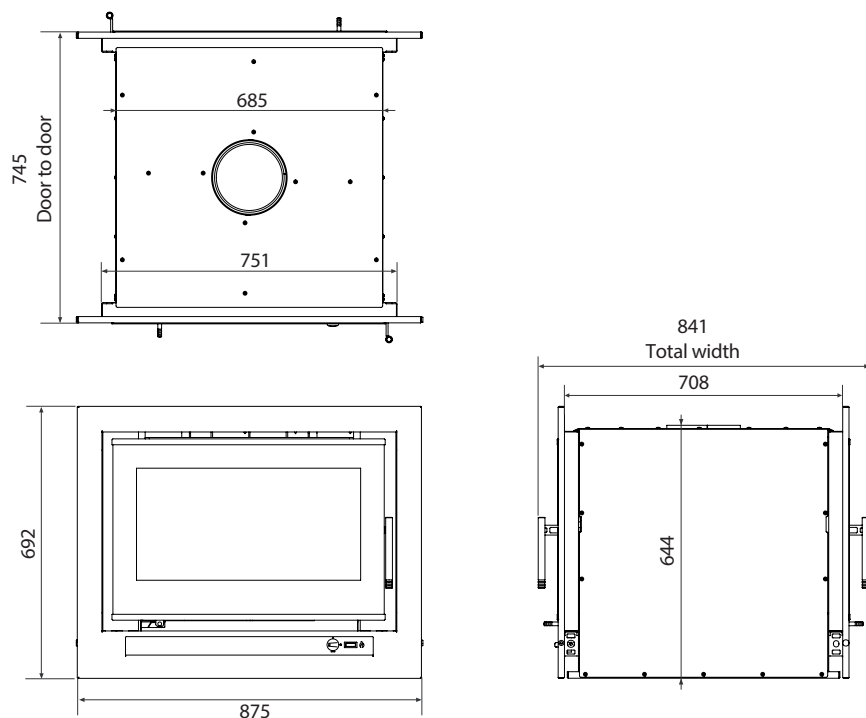
**Installation****WARNING****Installation**

THE INSTALLATION OF THIS APPLIANCE MUST BE CARRIED OUT AS PER THIS MANUAL AND THE FLUE MANUFACTURER'S SPECIFICATIONS.

WE RECOMMEND THAT YOU USE A QUALIFIED INSTALLER TO CARRY OUT THE INSTALLATION.

If you have any other enquiries, please contact the dealer from whom you purchased your heater.

THIS APPLIANCE WEIGHS IN EXCESS OF 200 KILOGRAMS. EXTREME CARE SHOULD BE TAKEN WHEN HANDLING THE APPLIANCE.

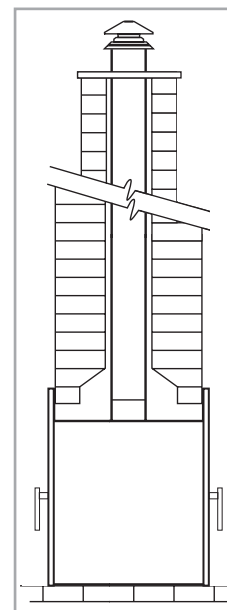

Section showing Installation
Figure 1. Masonry Installation

AF Gason Pty. Ltd. accepts no liability whatsoever for any interpretation of AS/NZS 2918:2001. It is important you understand these installation instructions and minimum clearances to combustible materials before selecting a position for your Eureka Jewel, to ensure safe and correct installation is achieved.

Installation permit

Depending on your local authority requirements, a permit may be required for the installation of your heater. It is your responsibility to arrange the same.

Installation into existing or masonry fireplace

The Eureka Jewel Insert can be installed into a masonry fireplace with a flue system that is in accordance with the relevant sections of AS/NZS 2198:2001.

In a masonry fireplace installation, the minimum hearth depth of 570mm from the front of the fascia panel on both sides must be achieved. In the instance the fireplace is raised above a combustible floor, and it is desirable to reduce the hearth depth, please refer to the elevated installation instructions on page 4 for hearth reduction information.

For detailed mantle clearance dimensions, refer Figure 3 on page 4.

If installing the Eureka Jewel under a combustible mantle, a hot air deflector must be attached onto the front of the fascia.

For additional clearance details, or access to the Eureka Jewel Insert Conformance Certificate, please contact your local Eureka dealer from whom you purchased your heater.

**WARNING****Brick Removal**

IF BRICKS REQUIRE REMOVAL WHEN PREPARING THE FIREPLACE, ENSURE THAT YOU DO NOT EXPOSE COMBUSTIBLE MATERIALS BEHIND THE BRICKWORK OR WEAKEN THE INTEGRAL STRUCTURE OF THE CHIMNEY.

Installation (continued)

Hearth & floor requirement

If the Eureka Jewel will be installed directly onto a non-combustible floor such as brick, stone or concrete slab with tiles, etc. which extends beneath the appliance as well as 570mm in front of the appliance fascia on both sides when in position, a hearth or floor protector may not be required.

At a minimum, the floor protector must extend 570mm in front of the appliance fascia on both sides, with a minimum overall depth of 1890mm and must be 940mm wide.

If the Eureka Jewel and hearth is to be installed directly onto or partially onto a combustible floor, a minimum 32mm thick non-combustible hearth or floor protector (cement sheet, Bellis Board, Hebal, stone or masonry, concrete etc.) must be placed in between the appliance and the combustible floor, directly beneath the unit. If the base of the unit is to be installed at an elevation less than 118mm above the top surface of the hearth, minimum hearth thickness is also 32mm. If the unit is installed at an elevation of 118mm or more from the the top surface of the hearth to the base of the unit, minimum hearth thickness (excluding directly below the unit) is reduced to 6mm.

Elevated installation

In some instances it may be desirable, or required that the Eureka Jewel Insert be installed into an existing fireplace which is raised above a combustible floor. In this situation, the minimum required hearth can be reduced to the corresponding elevated height dimensions mentioned in Table 1.

Scenario - The appliance is to be installed into an existing brick masonry fireplace which is situated 100mm above a combustible floor, at this height the minimum required hearth depth is 448mm in front of the appliance fascia. (refer Table 1.)

When the appliance is raised 176mm or more above a combustible floor, a 300mm non-combustible hearth or floor protector is always required as per AS/NZS 2918:2001.

Elevated installation details
(dimensions in mm)

Minimum Hearth Dept	Appliance raised by	Minimum Hearth Thickness
X	Y	H
570	0	32
553	20	32
530	40	32
505	60	32
478	80	32
448	100	32
433	110	32
420	118	6
416	120	6
398	130	6
379	140	6
359	150	6
338	160	6
315	170	6
300	176	6
300	≥176	6

Table 1. Appliance height vs hearth requirements

Elevated installation example - Figure 2

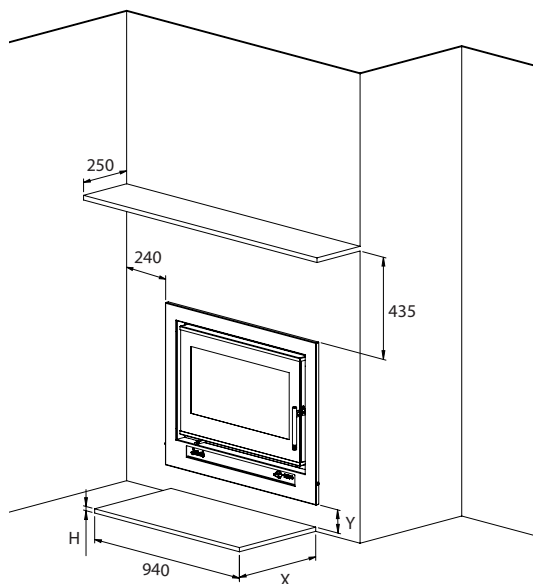

Firewood

Getting the most out of your firewood

Firewood is a sustainable source of energy and when used correctly can provide a cost effective form of heating in your home. Too often poor heating results and operational issues are attributed to using unseasoned wood which leads to excess smoking, causing creosote buildup and dirty glass. Wood should be stored in a dry place where good ventilation is available. Freshly cut wood should be stored for between 12-24 months before burning.

Use only hardwood with your Eureka Jewel.

Thermal efficiency

A wood's efficiency does not depend only on its type, but also on its moisture content as well as the temperature of the combustion chamber. To achieve a greater efficiency and longer burn cycle out of your Eureka Jewel, without the emissions of hazardous particulates, your wood must be well seasoned.

Ideally, wood should not be burnt when its moisture content is above 20%. A moisture meter to measure moisture content is a handy addition.

An example of available thermal efficiency for a piece of wood as a fuel source at varying moisture levels.

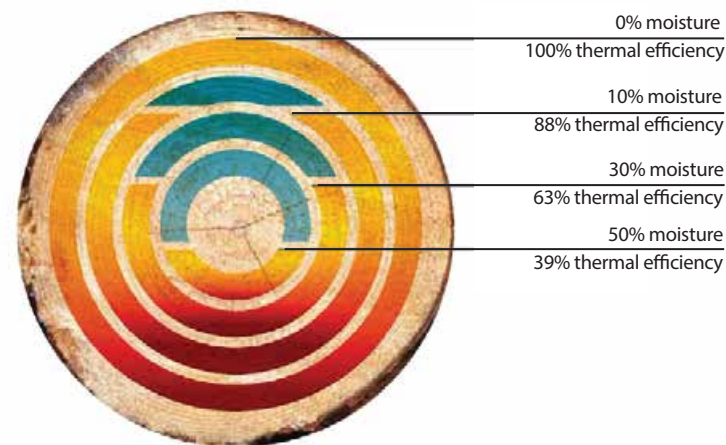

Figure 14

The combustion process of burning wood

When wood is heated up to approximately 100 degrees celsius, moisture begins to evaporate from the fuel. There is no heating value from the wood at this point. As moisture releases from the wood, it reduces the efficiency of the combustion process robbing heat energy from the wood. This demonstrates the importance of dry and well seasoned wood.

As firebox temperatures reach 250-300 degrees celsius, wood solids begin to break down and release volatile gases which ignite and produce heat.

From 300+ degrees celsius, the main energy available from wood is released when fuel vapors containing up to 60% of the wood's potential heat is released.

Understanding combustion principles and learning how to manipulate various conditions surrounding the operation of your Eureka Jewel enables you to achieve maximum comfort and efficiency from your Australian made wood heater.

Troubleshooting

• Noisy Fans

Turn the power off and remove the three pin plug from the power point. Remove the door on one side of the unit, then remove the fascia panel. Loosen the fascia fill panel retaining screws and lift panel up then out to remove. Note that wiring and switches are attached to this panel. Disconnect the wiring loom via the plastic joiner. Unscrew the wing nuts which hold each fan in position and remove the fans. Clean any dust with a dry paint brush and vacuum the fan blades. Clean around the motor. After completion place two or three drops of sewing machine oil on the shafts at the bearings. Replace the fans in reverse to the removal.

• Fans not working

Check the power connection with another appliance. If the power point is O.K. shift focus to the fan or the switches. Move thermostat switch into the 'Override' position, and select one of the three fan speeds. If the fans fail to function, isolate power as above, remove pedestal filler panel to gain access to loom. Check that the terminals on the loom and both switches are firmly connected. If the fans still fail to function, remove the fans and switches by firstly removing the knob from the rotary switch by pulling it away from the heater. Undo the holding nut and pull the switch out. Squeeze locator tabs together on the rear of the thermostat switch and push through outside of pedestal. Disconnect the wiring from the power lead and remove the fans. Convey the same to the authorised Eureka dealer from whom you purchased your unit for service. Replace in the reverse order.

• Air control jamming

Access to the airside is available when the door is opened. There are three screws holding the air slide in place. Undo them and remove the air slide. Wipe any ash or dust that may have accumulated on the back of the air slide or on the face of the heater. If any burrs have developed on the back of the air slide or on the face of the heater, rub them off with fine wet and dry sand paper till you have a smooth surface and edges. Replace the air slide and make sure the washers, springs and spacers are fitted when you screw the bolts back into the face of the heater. Do not apply any type of lubricant to the air slide whatsoever as this will attract dust and make the slide stick.

• No overnight burn

Remove the air slide as per air control jamming and check if the air slide is hard against the face of the heater. If it is loose, tighten up the bolts holding the air slide to the face of the heater. Do not overtighten.

Check that the door rope has an even indentation from its contact with the face of the firebox. If it is uneven and it appears as though air could leak through the seal, the door hinge and latch can be adjusted or the door rope may need to be replaced. Refer door adjustments and rope replacement instructions.

• Excessive ash build up

Some woods will give large amounts of ash despite how you run the heater. Others will give you very little. Use the wood which is most convenient for you, as long as it is dry. After a period of time you will get to know when to empty your unit. Bark will give you excessive ash. Try not to burn it. If you are burning wood that gives you charcoal, you may find that after running the heater say for 8 hours at maximum burn rate, the charcoal builds up excessively. An overnight burn will reduce this charcoal back to a fine ash. If you are not ready to shut down for an overnight burn when you next fuel the heater, load the heater with only one piece of wood and lay it across the firebox on top of the charcoal. Open the air control wide open and you will find the charcoal will burn down with the one piece of wood. Repeat the process until the ash level is significantly reduced.

• Excessive smoking - smoke entering the room maybe caused by:

- Insufficient length of flue (flue to be 4500mm minimum underneath the base of heater to underside of cowl)
Increase height of flue
- Flue downdraught - *Consult dealer or increase height of flue.*
- Creosote build up in flue - *Remove cowl and clean flue as per cleaning instructions. Check moisture content of wood.*



WARNING

Overfiring

TO PREVENT OVERFIRING OF THE HEATER, NEVER OPERATE THE HEATER WITH THE DOOR LOOSE, OR SUCH THAT THE FIREBOX IS NOT AIR TIGHT. OVERFIRING COULD RESULT IN DETRIMENTAL WEAR AND TEAR ON THE FIREBOX AND FLUE SYSTEM.

Installation (continued)

Baffle System



WARNING

Baffle System

If the baffle system is damaged, burnt out, discarded or not installed as per these instructions, high flue temperatures, losses in combustion efficiency and excess smoking can occur.

To operate this appliance as it is intended, and to ensure product longevity is achieved, ensure the baffle is installed as per these instructions.

If firebox, flue failure or excess damage to the appliance or its surroundings is reported due to incorrect installation or operation of the Insulated Baffle System, AF Gason Pty. Ltd. reserve the right to disallow any warranty or claims in relation to the abovementioned.

Fitting the steel baffle

CAUTION - Steel baffle is heavy (15kg) - seek assistance when carrying out baffle removal/installation.

1. Feed the baffle plate through the door opening with the upturned edges facing towards the door opening. Position the baffle in roughly the centre of the firebox.
2. Lift one edge of the baffle up over the baffle support bracket, lifting the raised edge as far into the upper corner of the firebox as possible.
3. Lift the other edge of the baffle up so that it is also above the height of the baffle support brackets.
4. Shift the baffle sideways so that it locates in the baffle supports on both sides of the firebox.
5. Ensure that the baffle is sitting level and that it is securely located in the baffle supports.

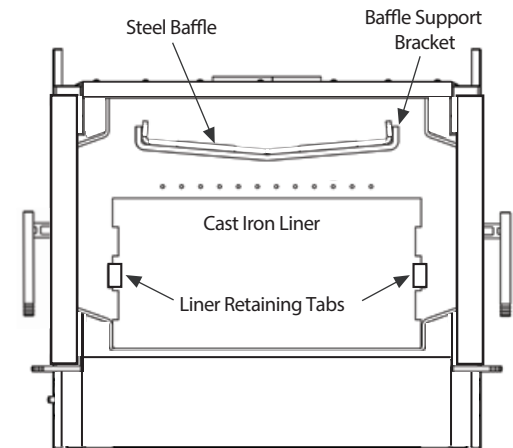

Figure 3

Placement of Cast Iron Liners into firebox

The cast iron liners are to be positioned with ribs and logos facing into the firebox.

To install cast iron liners, align the lower recesses of the cast iron liner and the retaining tabs in the firebox, then slip the liner over the retaining tabs and lower into position. Reverse this procedure for liner removal.

Final inspection prior to use

- Ensure the baffle is firmly located and in the correct orientation.
- Ensure cast iron liners are positioned correctly.
- Check fan cord has not been damaged during transit.
- Plug in fan cord and ensure cord does not touch heater surface.
- Switch thermostat switch to 'Override' and select one of three speeds to ensure fan is operational.
- Check door seals are in place.

Installation (continued)

Flue and chimney requirements

The flue pipe shall extend not less than 4.6m above the top of the floor protector. Note: Installation must be carried out by a licensed installer in accordance with AS/NZS 2918:2001.

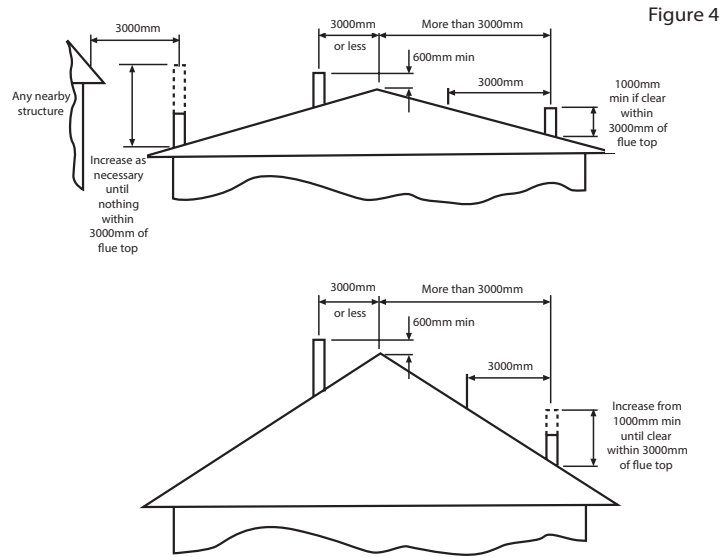

Figure 4

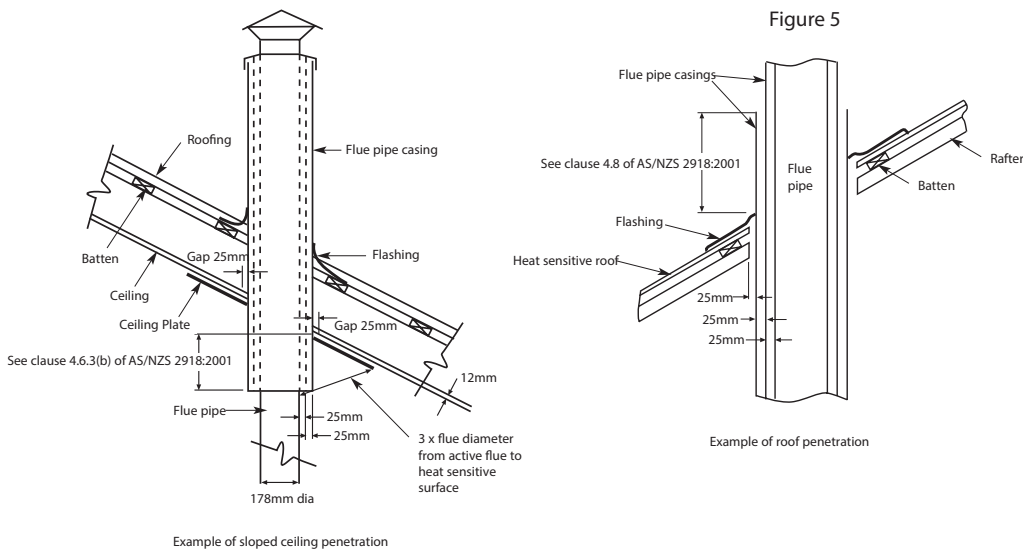
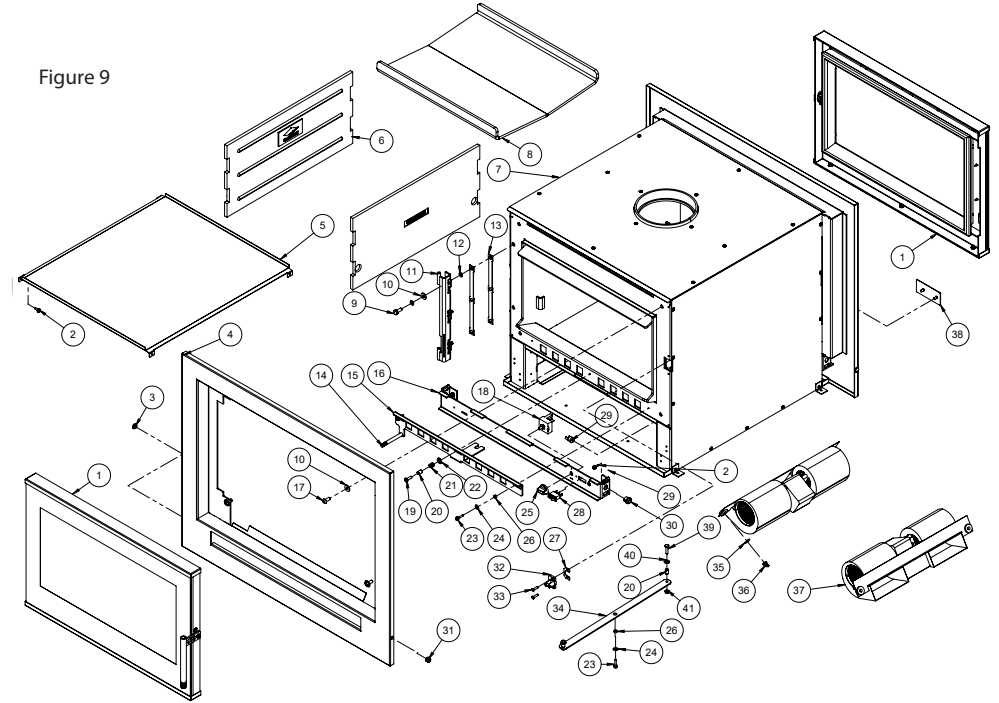

Figure 5

Basic Spare Parts

Figure 9



Ref.	GPN	Description	Ref.	GPN	Description
1	235529	Door Assembly	22	907400	Washer Flat 10 x 18
2	213151	Tek Screw 10-16 x 16	23	203902	Tek Screw 10-16x25
3	221328	Rubber Grommet Blank	24	906103	Washer Flat 3/16" x 9/16"
4	233884	Fascia Assy	25	227074	Switch Knob
5	236511	Lower Heat Shield	26	204184	Air Slide Bush
6	231030	Cast Iron Liner	27	234016	Latche Block Shim
7	233888	Insert Assy	28	232037	Switch - 2 Position
8	233881	Steel Baffle Plate	29	214289	Thermostat Switch
9	917333	Screw Set M8 x 20	30	203651	Grommet Cord Grip
10	907424	Washer Flat M8 x 20	31	213321	Rubber Grommet
11	230980	Hinge	32	234342	Catch Assembly
12	910106	Washer Star M8	33	917119	Screw Set M5 x 20 C/Sunk
13	234101	Hinge Shim	34	233883-01	Linkage Panel
14	231804	Air Slide Rod	35	906201	Washer Flat 1/4"x 3/4"
15	233882-01	Air Slide Panel	36	213146	Wing Nut M6
16	230568-10	Fascia Fill Panel	37	203903	Twin Barrel Fan
17	922334	Screw Cap M8 x 20	38	234278	Blanking Panel
18	213049	Switch - 3 Position	39	917203	Screw Set M6 x 25
19	917209	Screw Set M6 x 20	40	907208	Washer Flat M6x16
20	213098	Air Slide Spacer	41	903206	Nut M6
21	212974	Air Slide Spring			

Maintaining & Servicing your Eureka (continued)

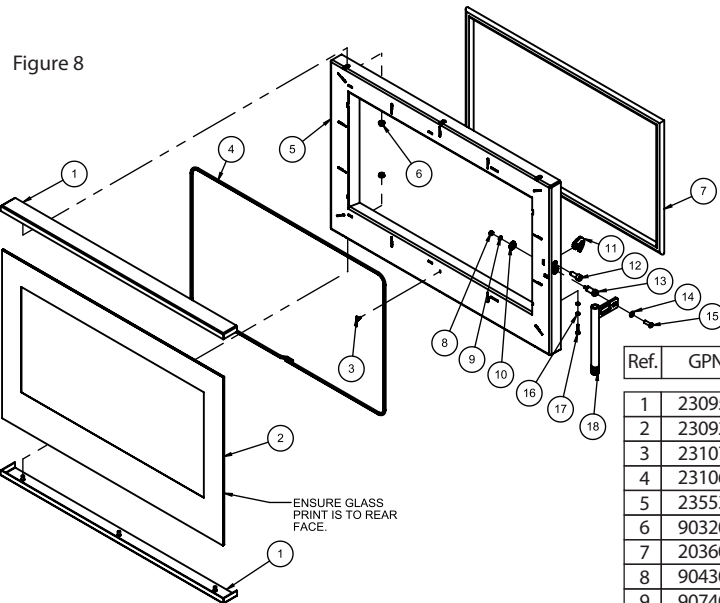

Ref.	GPN	Description
1	230954	Retainer
2	230922	Glass
3	231070	Dart Clips
4	231069	Rope 6mm OD
5	235536	Door Frame
6	903206	Nut Whizlock M6
7	203603	Rope 19mm OD
8	904300	Nut Conelock M5
9	907406	Washer M5.5x10
10	234344	Gear
11	234355	Catch
12	922311	Screw Set M8 x 20
13	231816	Shaft
14	907204	Washer M6x12.5
15	932202	Screw M6
16	902006	Nut M4
17	917007	Screw Set M4 x 20
18	231805	Handle

Replacing your glass

- Open door and lift free of hinge.
- Place door face down on a soft flat surface to protect paintwork and glass.
- Remove glass retainers by removing x6 M6 whizlock nuts.
- Lift door frame away from glass. Note how the 6mm OD glass sealing rope is placed around the door frame - dispose of old glass safely.
- Fit new 6mm OD glass sealing rope onto the door frame with new x6 dart clips. Ensure clips are positioned with pointed extrusion facing towards the edge of the door frame.
- Place the glass back onto the door frame with the 6mm OD door sealing rope in position.
- Fit glass retainers back to top and bottom of the door, and attach to door frame with the x6 M6 whizlock nuts. Tighten nuts evenly until the retainer holds the glass. Do not over tighten the retainers as this could break the glass.
- Mount door back onto hinge, close and ensure fitment safe and correct.

Fitting a new door seal

- Open door and lift free of hinge.
- Place the door face down on a soft flat surface to protect the paintwork and glass.
- Remove old rope and scrape old glue from rope retaining groove.
- Clean the rope retaining groove with a clean, dry cloth to remove any old dust and debris.
- Apply a generous bead of roof and gutter silicon around the rope retaining groove.
- Press the new 19mm OD door rope into the rope retainer groove, placing the start-stop joint to the bottom corner of the hinge side of the door.
- Refit door, and close to apply pressure to the new rope.

Note: Hinge and door catch may need to be adjusted to allow the door to close completely, if previously adjusted to accommodate an ageing rope.

- Leave door closed for at least 12 hours before lighting the heater, and initially run at a low temperature to allow adhesive to fully bond to the door.

Operating your Eureka



DO NOT ATTEMPT TO OPERATE THIS APPLIANCE WITHOUT READING AND UNDERSTANDING THESE OPERATING INSTRUCTIONS THOROUGHLY. FAILURE TO OPERATE THIS APPLIANCE PROPERLY MAY CAUSE UNDUE DAMAGE TO THE APPLIANCE OR RESULT IN A FLUE FIRE.

Starting your fire

Place a firelighter or paper in the bottom of the firebox and place a large amount of small kindling on top. Ignite the paper or the firelighter. Set the air control to High and leave the main door open approximately 25mm. When the kindling is burning, place about four pieces of small wood on top of the burning kindling. Once the wood is alight, close the main door. After approximately 20 minutes, turn the air control down to Medium. For fan operation refer page 8.

On the initial fire up you may detect smoke coming from the paint finish and from any oils that may be on the steel on the outside of the firebox. This is normal. It is suggested to well ventilate your home on the initial fire up. Please refer to our section 'Paint Curing and Care' on page 2.

The glass door

Always operate your heater with the door closed and locked. The only time you can leave the door open is on initial lighting, or when reloading the heater.

Care of your glass

If you are burning good dry wood, you will have very little discolouration of your glass in normal burning cycle. If you aim for an eight to ten hour overnight burn, you should not get much discolouration. You can control this by adjusting the air control, moving from the left and slowly creeping the control to the right. After a number of days you will find the right position to suit your requirements and the fuel that you are using.

Daily operations

When you get up in the morning, open up the air control of the heater to High position to start the embers glowing. Place three or four pieces of wood on top of the embers and leave the door open 25mm. Once the fuel starts to flame close the door. Depending on your daily heating requirements, operate the fan as per fan operation instructions on page 8. For best results it is best to burn 410mm long wood and load your wood straight into the firebox front to rear. This will give optimum efficiency and recoverable heat, and minimise creosote formation and smoke emissions.

Overnight burn

Approximately 30 minutes before turning the heater down for the overnight burn it is recommended to load the heater with fuel. Leave the air control in the Medium to High position. Let the heater run for about 30 minutes. This will reduce the moisture content in the fuel before shut down. (This will help reduce the creosote formation in the firebox and flue.)

Set the air control to the setting you have found best for your requirements. Turn the fan off or to the thermostat control position and retire. The aim when overnight burning is to have only a few hot embers left in the bottom of the firebox in the morning, not huge lumps of wood.

Fan operation

Your Eureka Jewel is equipped with a temperature-sensitive thermostat switch located within the heater's pedestal beneath the firebox, which when selected will turn the fan on and off depending on the temperature of the firebox.

To use the thermostat, select the thermostat 'On' position via the thermostat switch, and select the desired fan speed you wish to use (Low, Medium or High).

If the fan is not coming on at the desired time, flip the switch into the override position and operate the 3 speed fan as described on page 8, with reference to figure 6.

Operating your Eureka (continued)

Initial Startup (cold)

Leave fan off until the heater is hot and has established a coal bed - approximately 20 minutes after fuel is lit.

Medium or High Burn Setting

If the heater is running above medium fire for extended periods of time, fan speeds Medium and High are recommended. High is recommended for short bursts where a quick temperature rise is desired in conjunction with a high fire setting.

Low Burn Setting

The fan cools off the firebox, robbing the combustion process of efficiency. It is acceptable to turn the fan off, only when the heater is burning a low fire.

Note: Improper use of fan can result in firebox failure.

The fan should be cleaned on a regular basis. (Refer Troubleshooting for fan removal and cleaning.)

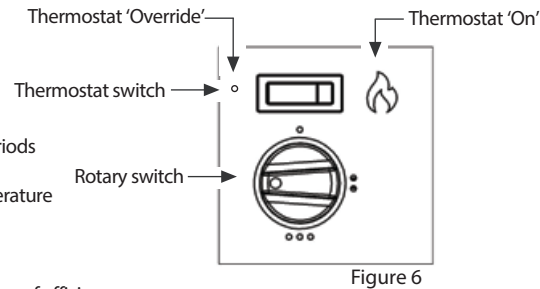

Figure 6



WARNING

Operation of the Fan

If firebox failure is reported and it is found that the firebox has been abused through improper use of the fan, AF Gason Pty. Ltd. reserve the right to disallow any warranty claims in relation to firebox failure.



WARNING

The Door

Leaving Door Open

As stated previously, leaving door open 25mm encourages the fire to pick up at a faster rate. Your heater has been tested to ensure that no structural damage can take place if the door is inadvertently left open. However your paint finish can be damaged if the door is left open for a long period with a full firebox of fuel with the fan off. Closely supervise your heater while the door is left open.

Closing the Door

Always ensure that before you close your door there is no wood protruding beyond the front of the firebox opening. Do not use the door glass as a 'battering ram' to push the wood back into the firebox. Damage to the glass by such impact is not covered by your warranty.

Maintaining & Servicing your Eureka

Cleaning your flue

Firstly and carefully remove cast iron plates and baffle system and put to one side. Close the heater door. Obtain a 180mm flue brush from your local Eureka Dealer and proceed to the top of the flue. Remove the flue cowl. Slowly push the brush down the flue until it stops. Pull the brush back out and repeat the process. Each time you do this you will notice that the brush will go further down the flue until it reaches the bottom. The soot and creosote will fall down the flue and into the firebox. Clean residue from firebox. Replace the baffle plate first followed by the cast iron liners. Make sure you do the job well. The cleaner the flue the less chance there will be of the creosote sticking again. After you replace the cowl, inspect the roof flashing for any damage that may have incurred whilst you were cleaning the flue. Reseal the seal on the roof with roof and gutter silicon if required.

Maintaining & Servicing your Eureka (continued)

Cleaning the glass

Generally the only time you will possibly need to clean your glass is after a long overnight burn. If you find that you have a wet sticky black film on your glass (creosote), it is better to burn the heater as normal for one load of wood. When the wood has burnt down to a hot bed of embers, open the door and leave it wide open until the glass cools sufficiently to be wiped with a damp cloth. This should clean all the white smoky film off the glass. Creosote on the glass is normally a sign that you have tried to get too long an overnight burn or you have burnt excessively wet or green wood. If the film on the glass won't come off with a wet cloth, you can use wet ash from the ash bed as a cleaner or commercial products such as Crystal Clear, Johnson Foam Clean or Windex.

To maintain an efficient and safe use of your Eureka Jewel, you may need to adjust the door hinge and catch to ensure the door closes safely and correctly over the duration of its life.

Adjusting door catch

- Open door to gain access to catch.
- Using a 3mm Allen key, remove the two catch retaining screws and set aside.
- To tighten the latch, remove one shim. To loosen the latch, fit an additional shim.
- Additional shims are provided in the user manual packaging. Refer to figure 11-1.
- Once the desired setting has been achieved, re-fit the catch assembly using the two retaining screws.
- Note that if an adequate seal cannot be achieved through the removal of one shim, a replacement door rope may be required.

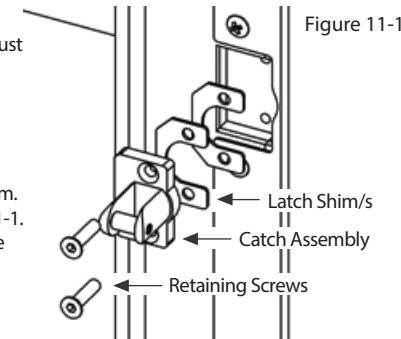

Figure 11-1

Adjusting door hinge

The door hinge defines the door alignment to the heater and the door catch, as well as determining the amount of pressure applied to the main door rope at the hinge side of the door.

To align door:

- Slightly loosen 3 x M8 Bolts securing the hinge to the heater. The upper bolts should be loosened 1- 1+1/2 turns, while the lower bolt should only be loosened 1/2 a turn.
 - Align door horizontally by pivoting the door about the lower bolt. Note that there is no provision for lateral adjustment of the door hinge position.
 - Check the alignment of the door by measuring vertically from the underside of the door at each outer edge, to the base of the unit, as per figure 11-2.
- This measurement should be taken with the hinge bolts tightened and with the door hanging under its own weight.

To adjust hinge shims:

- Open door and lift free of hinge, and place on a soft flat surface while servicing the hinge.
- Remove the door hinge and fasteners as shown in figure 11.3.
- Remove x1 hinge shim plate in order to tighten the seal of the door rope. The maximum number of shims permitted behind the hinge is 2, fitted as standard.
- Fit door and re-align door to catch and firebox before fully tightening M8 bolts.

Adjusting door handle

- The door handle position can be adjusted to align the handle with the door glass, when the handle is in the closed position.
- Adjustment is carried out by winding the adjuster screw in or out, in order to change the rest stop position of the handle. This should be done with the door open and the handle resting in the closed position.
- To adjust the position of the screw, first release the lock nuts, then use a Phillip's head screw driver to turn the adjuster screw either in or out depending on the adjustment required.
- Once the desired adjustment position has been achieved, the lock nut should be re-tightened against the retaining plate. Refer to figure 11.3.

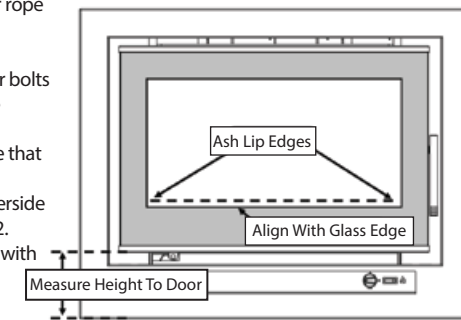
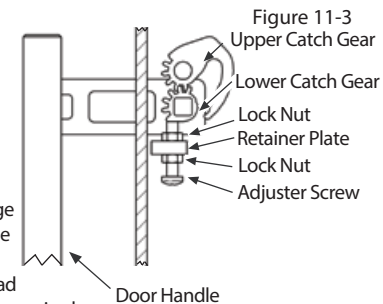

Figure 11-2

Figure 11-3
Upper Catch Gear